

by **C.A.E. PERFORMANCE PRODUCTS**

P.O. Box 686, Castlemaine, VIC. 3450

T 03 5472 1442

F 03 5472 4111

E info@caenterprises.com.au

W www.hitorque.com.au



Fordson Tractors

Customer Instructions for Fordson Tractors with the new Gear Reduction Starter which replaces the old Lever type starter.

- 1) If the starter needs to be rotated on the aluminium end plate, Undo the two Cap screws and mount the aluminium end plate to the engine then fit and mark the position of the starter on to the end plate at the correct position to give correct clearances around the starter. Some applications require the top mounting bolt to be pre fitted before the aluminium plate is rotated. Remove plate and starter and fit the two cap screws in the index holes selected. Use a drop of locktight on the cap screws. These starters can hang down or be vertically mounted.
- 2) Reconnect the original starter cable to the 10mm stud on the new starter, but at the solenoid end of this cable, remove it from the solenoid stud terminal and place it on top of the main battery cable on the other side of the solenoid. These two cables are now one common power supply to the new starter.
- 3) Run a new wire supplied from the starter motor small terminal up to the solenoid cut this cable to the correct length and connects it to the solenoid terminal that you removed the original starter cable from. This now makes the old solenoid into a relay for the Gear Reduction Starter Motor.
- 4) Mount the Starter Press button supplied in a convenient place and connect the two wires to the two original wires removed from the old Lever Switch that was part of the old original Starter. This will now energise the slave solenoid to feed power to the new Gear reduction starter solenoid.

by **C.A.E. PERFORMANCE PRODUCTS**

P.O. Box 686, Castlemaine, VIC. 3450

T 03 5472 1442

F 03 5472 4111

E info@caenterprises.com.au

W www.hitorque.com.au

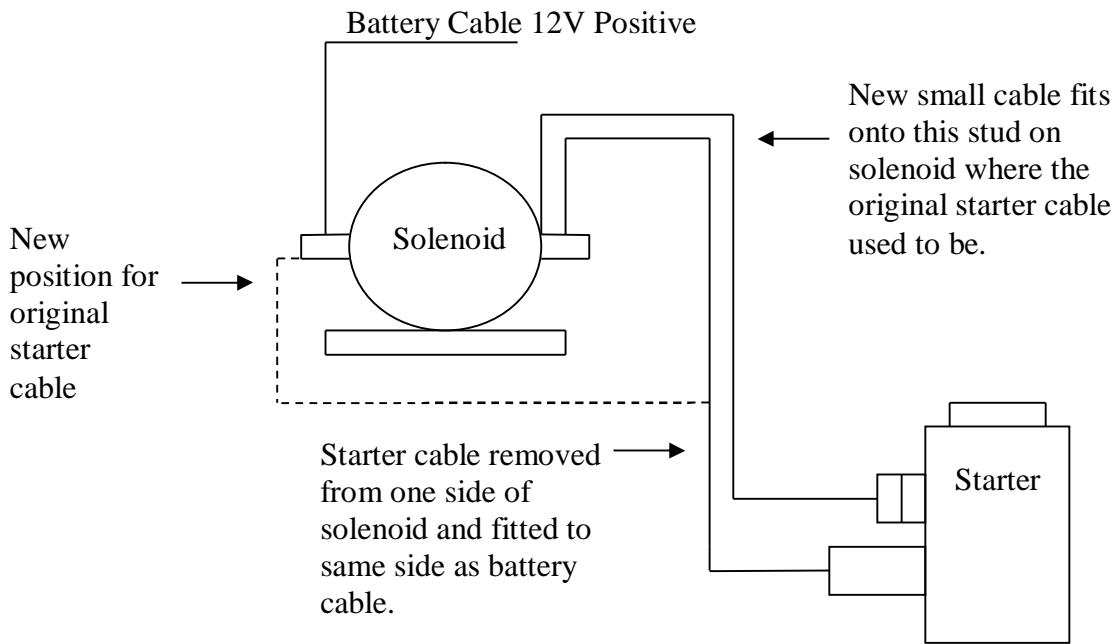

Two wires from the old lever starter switch, get joined to the two wires supplied with the Press Starter Switch.

by **C.A.E. PERFORMANCE PRODUCTS**

P.O. Box 686, Castlemaine, VIC. 3450

T 03 5472 1442

F 03 5472 4111

E info@caenterprises.com.au

W www.hitorque.com.au



Warranty

The manufacturer's warranty on all Hi-Torque gear reduction starter motors is for a period of (1) Year, covering the Starter Motor ONLY. The Warranty is subject to the following conditions.

Warranty Conditions

- All claims must be made in the warranty period of 12 Months.
- Any starter motor found to have faulty workmanship will be replaced free of charge.
- This warranty does not apply to items that have been subject to neglect, misuse, abuse, accidental or intentional damage, unauthorized repairs, modifications, incorrect application or installation. *Please check description below.
- The warranty does not cover the cost of freight, installation or removal of items.
- The warranty of 12 months only applies to items being used for normal road use.
- C.A.E. Performance Products recommend that this product be fitted by qualified personnel.

**Starter motors that have been misused or abused include the following: Water damage, Over heated, Pinion engaged while driving or hi revving and Extreme dust or corrosive conditions.*

It's up to the purchaser/ installer to ensure the starter motor is sealed or protected if used for Off Road or Marine applications.

ORDERING

Orders can be placed by phone, fax or e-mail. We prefer official purchase orders from account customers. Please quote the part number, quantity and any special requirements when ordering.

SHIPPING

All orders are dispatched upon payment (except account customers). We ship Australia-wide every day. If you wish to use your own courier, please advise us of your courier name & account details & we can organize pick-up. Transport insurance can be arranged at the request of the purchaser.

RETURN OF GOODS

All part returned will incur a 20% re-stocking fee. Returns must be made within 30 Days. Freight is to be paid by customer unless the goods are being returned due to manufacturing defect or shipping error, in which case they are to be shipped using our Australia Post Reply Paid account. C.O.D. post will NOT be accepted under any circumstances. Goods specifically made to customer requests cannot be returned for credit. All goods remain the property C.A.E. Performance Products Pty Ltd until paid for in full.

DAMAGE

All goods are shipped in good condition & are packed accordingly. We can only handle damage claims for prepaid freight.

PAYMENT

Payment can be made by credit card, direct deposit, cheque/money order or cash over the counter. Please note that cheques & money orders must include the full amount of the order & freight costs. Personal cheques are subject to bank clearance (5 business days).